



**Getting Started with
Palm™ m100 Series
Handhelds**

Copyright

Copyright © 2001-2002 Palm, Inc. All rights reserved. Graffiti, HotSync, and Palm OS are registered trademarks of Palm, Inc. The HotSync logo, Palm, Palm Powered, and the Palm logo are trademarks of Palm, Inc. Other product and brand names may be trademarks or registered trademarks of their respective owners.

Disclaimer and Limitation of Liability

Palm, Inc. assumes no responsibility for any damage or loss resulting from the use of this guide.

Palm, Inc. assumes no responsibility for any loss or claims by third parties which may arise through the use of this software. Palm, Inc. assumes no responsibility for any damage or loss caused by deletion of data as a result of malfunction, dead battery, or repairs. Be sure to make backup copies of all important data on other media to protect against data loss.

IMPORTANT Please read the End User Software License Agreement with this product before using the accompanying software program(s). Using any part of the software indicates that you accept the terms of the End User Software License Agreement.

Software Download Available

Palm™ Desktop software is supplied on a CD-ROM disc. If you do not have access to a CD-ROM drive for your computer, you can download Palm Desktop software from www.palm.com.

Agency Compliance Information

Product regulatory and compliance information can be found in the Handbook file located on the product CD-ROM.

Contents

Front panel of Palm™ m100 series handhelds	1
Back panel of Palm m100 series handhelds	1
Graffiti® writing area and surrounding icons	2
Graffiti writing	3
Basic Graffiti characters (there are many more).	3
Tips	3
Applications on your handheld	4
Tips	4
Menus	10
Expansion card	10
Beaming information.	11
Battery Power	12
Removing the flip cover	13
Changing the faceplate	13
Palm™ Desktop software	14
System requirements	15
Troubleshooting	16
I don't see anything on my handheld screen	17
I can't complete a HotSync operation	17
Troubleshooting communication problems	18
Troubleshooting data synchronization problems	20
Troubleshooting recharging problems	21
Troubleshooting expansion card problems.	21
Index	23

Front panel of Palm™ m100 series handhelds

Power button

Press it to turn on your handheld. Hold it down for two seconds to set the brightness of the backlight. Press it again to turn it off.

Date Book

Address Book

Application buttons

Press each one to turn on the handheld and start an application.

Note Pad

To Do List

Graffiti® writing area

See the next page for details. Graffiti writing is a simple method of writing letters, numbers, and symbols.

Scroll buttons

Press to scroll through screens, go from day to day in Date Book. When your handheld is off, press the Up button to display the Clock.

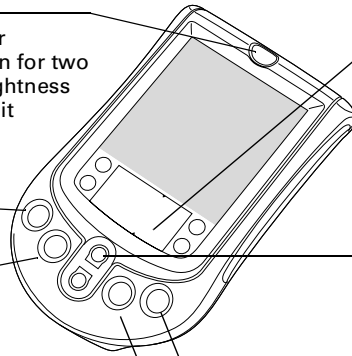

Back panel of Palm m100 series handhelds

Stylus

The tool for everything you do on the handheld. Use it to write Graffiti characters, tap icons and buttons and menu items, select text, drag the scroll bar, and so on.

Universal connector

Your handheld's connection to the HotSync® cradle/cable, and also to a modem, portable keyboard, and other accessories that are sold separately.

Faceplate tab

See page 13 to learn how to change the faceplate.

IR port

Beam data from your handheld to another Palm OS® handheld. See page 11 for details.

Expansion card slot

Increase the space available for data and applications. See page 10 for details.

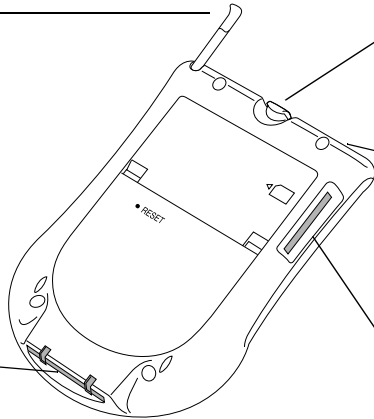

Graffiti® writing area and surrounding icons

Tap **Clock** to see the time, set an alarm, change the time and date.

Tap **Contrast** to improve screen contrast using slider.

Tap to open the **Applications Launcher**. All your applications are listed there.

When writing **Graffiti characters**, write letters on the left, numbers on the right.

Tap to open the **Calculator**.

Tap to see **menus** in applications that have them.

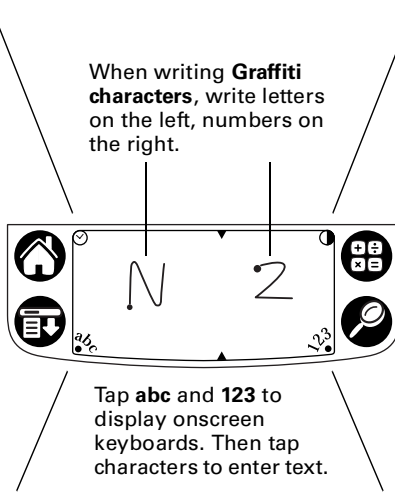

Tap to **find** text in all applications.

Tap **abc** and **123** to display onscreen keyboards. Then tap characters to enter text.

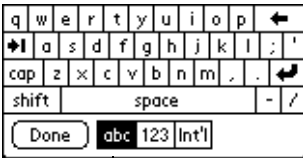

Tap here to display alphabetic keyboard.

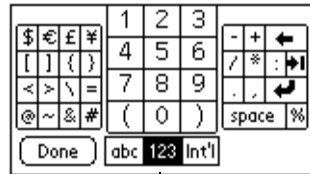

Tap here to display numeric keyboard.



Tap here to display international keyboard.

Graffiti writing

The best way to learn is to practice. To take the Graffiti tutorial on your handheld, tap the Graffiti icon in the Applications Launcher.

Most Graffiti characters are made with a single stroke of the stylus.

1. Start the stroke where the heavy dot is. Don't try to make the dot; just start there.



2. Don't lift the stylus until you reach the end of the stroke.

Some characters require a preliminary stroke. For example, to write a quotation mark, tap once and then make the Graffiti stroke for n.

Basic Graffiti characters (there are many more)

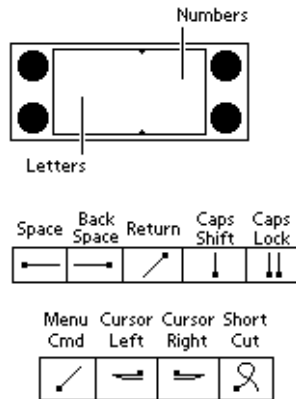
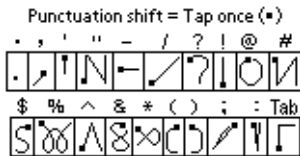

Tips

- Characters do not show up in the Graffiti writing area, but on the handheld screen, wherever the blinking cursor is located in the record you're working on.
- Write Graffiti characters BIG, and write at normal speed.
- Press firmly with the stylus.

- You can see tables displaying all Graffiti characters simply by drawing the pen stroke: starting from the bottom center of the Graffiti writing area, drag the stylus to draw a straight, imaginary line to the top of the screen.
- You can write Graffiti characters even when the onscreen keyboard is open.

Applications on your handheld



In the Applications Launcher, the **category** All shows you all the applications on your handheld. Tap All to select another category from the pick list that drops down. Select Edit Categories to create a new category.

Use the stylus to drag the dark bar of the **scroll bar** so that you can see the rest of the icons on the screen. Or press the Down scroll button.

Tips

- To start an application, tap its icon.
- Tap the Welcome icon in the Applications Launcher to go through the Basic Skills and Graffiti tutorials.
- Complete descriptions of the applications are in the electronic *Handbook*.
- For help on a task, tap the Tips icon (ⓘ) on your handheld.



Address Book. Keep names, addresses, phone numbers, and other information about your personal and business contacts. Enter a last name on the Look Up line to jump to that name.

Address		▼ All
Ulrick, Renate	415-555-5364W	
Vinsky, Lidya	415-555-7311W	
Vishnu, Kassim	415-555-2231W	
Vogel, Christine	650-555-6564W	
Wagner, Pat	408-555-1953W	
Walker, Nancy	415-555-7882H	
Weston, Michelle	408-555-1212W	
Wilkes, Jay	831-555-6537W	
Wong, Kai	650-555-5858W	
Wright, James	451-555-2485W	
Yanowski, Mark	408-555-5258W	

Look Up: wes

Address View		Business
Michelle Weston		
Sr. Product Mktng. Mgr. Example, Inc.		
Work:	408.555.1212	
Home:	650.555.2123	
Fax:	408.555.1322	
Pager:	650.555.3333	
E-mail:	mweston@example.com	
4552 Sanchez St. Santa Clara, CA 95052		
<input type="button" value="Done"/>		<input type="button" value="Edit"/> <input type="button" value="New"/>



Calculator. Perform addition, subtraction, multiplication, division, and square root operations. In the Options menu, tap Recent Calculations to see the calculations you made in the current session.



Card Info. Name expansion cards, format them, and review general information about a card and its contents.

Card Info	
Card:	▼ My Card
Type:	MultiMedia Card
Size:	3 MB Free of 3 MB
Application Directory:	
	3 Applications, 105 KB



Clock. View the current time and date. Set a wake-up alarm here. In the Options menu, tap Alarm Preferences to select Reveille, Bumble Bee, or other sounds.



Date Book. Schedule appointments or any activity associated with a time and date. A diamond marks an untimed event. Tap icons in the lower-left corner to see events in the Day, Week, Month, or Agenda view.

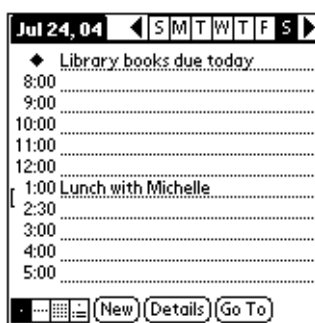

Graffiti. Tap to start the Graffiti tutorial.



HotSync. HotSync operations exchange and update data between your handheld and your computer. You can perform HotSync operations using a cradle or cable, modems attached to your handheld and desktop computer, and the IR ports on your handheld and computer. When synchronization is complete, the following screen appears:



Memo Pad. Store notes, directions, passwords, and other information you can't always remember. Each memo can be up to 4,000 characters long. In the Options menu, tap Font to make text bold or large.

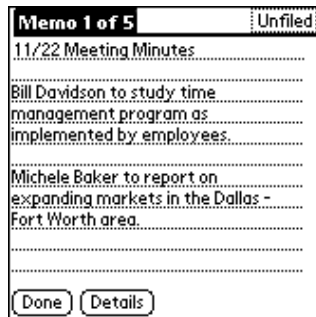



Note Pad. Work on the screen to make notes in your own handwriting, draw maps, sketch, and so on.

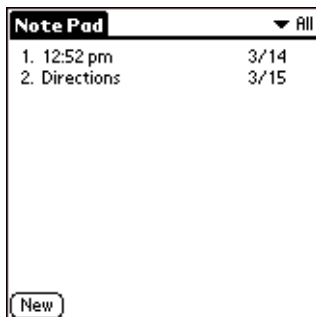
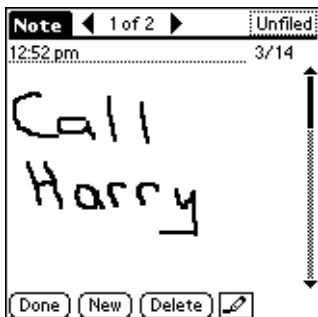

Preferences. Customize the way your handheld looks and operates. Tap the pick list in the upper-right corner to go to the various preferences screens.

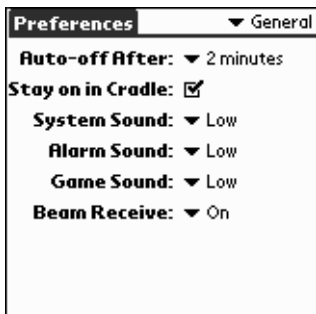



Security. Set a password here and select whether to mask your private records or hide them completely. Use the same password to lock your handheld.

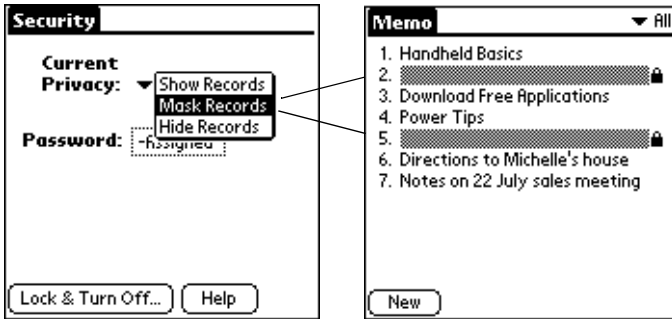

To Do List. Create short reminders of what you have to do. Tap Details to prioritize an item. Use Agenda View in Date Book to see your schedule and To Do List items together.

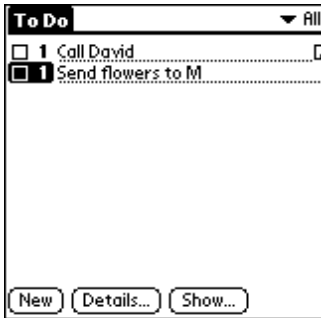

Welcome. Come back here to recalibrate your screen or review the Basic Skills and Graffiti tutorials.

Menus

To use menus, tap the Menu icon, or tap the upper-left corner of the screen. The first menu drops down. Tap a menu to open it, and then tap a command to choose it.



Tap the Menu icon (shown at left) in the Graffiti writing area to display the first menu.

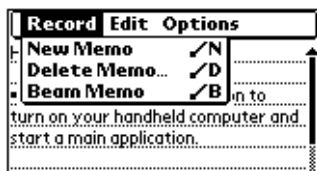

To use common commands available in your current context, draw the Graffiti Menu Command stroke. A toolbar appears. Tap the icon of the command you want.

Graffiti Menu Command stroke

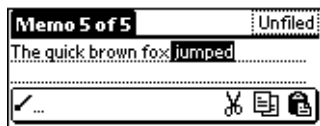

In this context, Cut, Copy, and Paste are available. Just tap an icon.

Expansion card

A tiny Secure Digital (SD) or MultiMediaCard expansion card (sold separately) increases the variety of tasks you can do and the amount of space available for storing software and data on your handheld.

To insert a card:

1. Insert the card in the direction shown by the icon.
2. Push the card in with your thumb. You feel the card lock and hear the system sound (if sound is on).

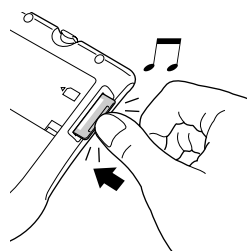
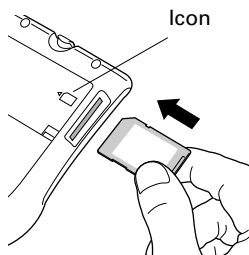

To remove a card:

1. Push lightly against the card with your thumb.
2. When the card is released, you hear the system sound.

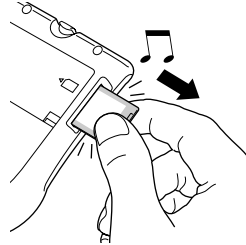
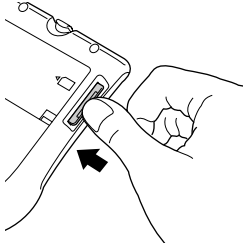

When a card is seated in the expansion slot, its name appears in the upper-right corner of the Applications Launcher, and its contents appear onscreen, as shown to the right.



When you want to go back to the applications on your handheld, tap the name of the expansion card, and then tap All in the pick list.

Use the Card Info application to see general information about the expansion card, rename it, and format it.

Keep the expansion card slot clean. Leave the dummy card in the slot when you are not using an expansion card.

Beaming information

The infrared (IR) port on your handheld can beam information to another Palm OS® handheld with an IR port that's close by.

You can beam the following information:

- The record or category of records currently displayed in Address Book, Date Book, Memo Pad, Note Pad, or To Do List.
- An application in RAM memory or on an expansion card.
- An Address Book record designated as your business card. To designate the record, simply select the record, tap the Menu icon, tap Select Business Card, and then tap Yes to confirm. To beam your business card, hold down the Address Book button for two seconds.

For best results, handhelds should be between 10 centimeters (about 4 inches) and 1 meter (about 39 inches) apart, and the path between the two handhelds must be clear of obstacles.



To beam:

1. Display what you want to beam onscreen.
2. Tap the Menu icon.
3. In the menu that drops down, tap the Beam command.

To receive beamed information:

1. Turn on your handheld.
2. (Optional) Tap the category pick list and select where you want the information to be stored on your handheld.

Before you move your handhelds out of beaming position, wait for the Beam Status dialog box to indicate that the transfer is complete.

Battery Power

Your handheld is recharged each time you place the handheld in the cradle. Just place your handheld in the cradle for at least two hours for an initial charge before you use it. Then place it in the cradle for ten to fifteen minutes each day to recharge the battery to full capacity.

If the battery gets low, your handheld displays a warning message. If this occurs, perform a HotSync operation and then recharge the battery as soon as possible. If your handheld shuts down, you still have about a week to recharge the battery before you lose the data on your handheld.

Removing the flip cover

To remove the cover:

1. Grasp the hinge with your thumb.
2. Gently rock the cover from one side to the other until the hinge prongs release from the handheld.

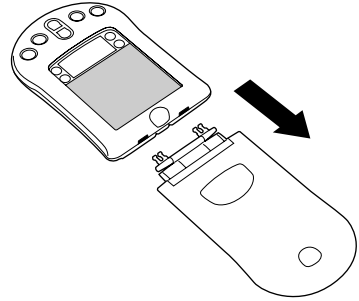

Changing the faceplate

To remove the faceplate:

1. Remove the flip cover.
2. Lift the faceplate tab slightly to separate it from the handheld; then pull the faceplate away from the handheld.

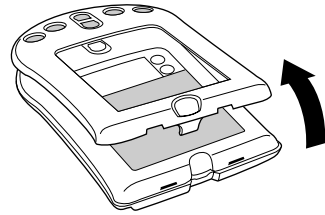

To attach the faceplate:

1. Align the bottom edge of the new faceplate with the slot on the bottom edge of the handheld.
2. Gently press the top of the faceplate onto the handheld until it clicks into position.



Palm™ Desktop software

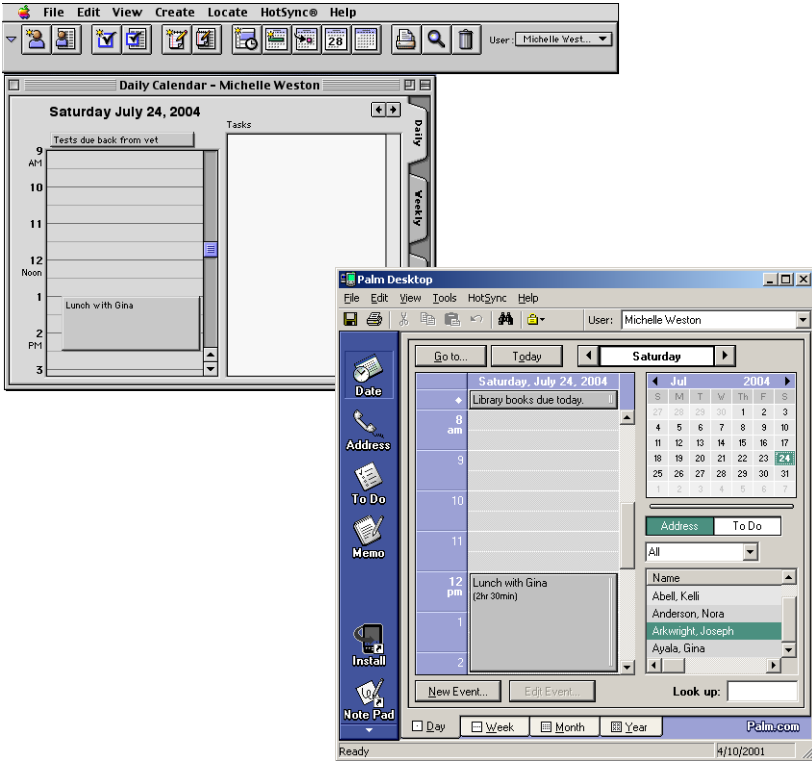

Here are four important reasons why you should use Palm™ Desktop software:

Synchronize to keep your data safe. Develop the habit of performing frequent HotSync operations between your handheld and Palm Desktop software. Then, should anything happen to your handheld, you have a copy of your data in Palm Desktop software.

Enter data in an application on your computer. Then perform a HotSync operation. The data shows up in the corresponding application on your handheld, and data from the handheld shows up in the appropriate application in Palm Desktop software.

Download Palm™ applications from the web to the Palm\Add-on folder on your computer. Then:

Windows computer. Click the Install Tool icon.

Mac computer. From the HotSync menu, choose Install Handheld Files.

On either platform, add the application to the Install Tool list and indicate whether the application is to be loaded on your handheld or an expansion card. Then perform a HotSync operation. The application is loaded onto your handheld or expansion card.

Consult the electronic Handbook. Adobe Acrobat Reader opens the comprehensive documentation for your handheld. (If you do not have Acrobat Reader, install it from the CD-ROM labeled Palm Desktop software.) To open the *Handbook*, do one of the following:

Windows computer. From the Help menu of Palm Desktop software, choose Handbook.

Mac computer. Open the Palm folder, and then open the Documentation folder. Double-click the file Handbook.pdf.

The *Handbook* table of contents is located in the pane on the left side of Acrobat Reader. To jump to a section of the book, click the section in the table of contents. You can also click Index to find what you're looking for; then click the index entry to jump to the page.

System requirements

To install and operate Palm Desktop software, your computer system must meet the following requirements:

Minimum requirements: Windows

- IBM-compatible Pentium-class computer
- Windows 95*/98/Me/NT 4.0*/2000**/XP** (* Windows 95/NT operating systems require a serial cradle/cable, sold separately. ** User must have administrator rights to install Palm Desktop software.)
- 30 MB available hard disk space
- VGA monitor or better (16 bit or High Color, and 800 x 600 resolution recommended)

- CD-ROM or DVD-ROM drive (you can also download the Palm Desktop software from www.palm.com)
- Mouse
- One available USB port or serial port (serial cradle/cable sold separately)

Minimum requirements: Mac

- Mac computer or compatible with a Power PC processor
- Mac OS 8.6 to 9.x
- 25 MB available hard disk space
- 6 MB available RAM
- CD-ROM or DVD-ROM drive (you can also download the Palm Desktop software from www.palm.com)
- Mouse
- One available USB port or serial port (serial cradle/cable sold separately)

Troubleshooting

If you encounter a problem, try the following:

- The suggestions included in this section.
- The suggestions in the “Frequently Asked Questions” appendix of the electronic *Handbook*, accessible from Palm Desktop software.
- The Support pages on the Palm web site: www.palm.com.

If your problem persists, contact Technical Support. For US and international telephone numbers, go to the Palm web site: www.palm.com.

Third-party applications. There are thousands of third-party applications available for Palm OS handhelds. For questions and support, please contact the software developer directly.

I don't see anything on my handheld screen

1. Press an application button to ensure your handheld is turned on.
2. Tap the Contrast icon  in the upper-right corner of the Graffiti writing area. If the Contrast dialog box appears, adjust the contrast by holding down the Up scroll button for a few seconds. If this doesn't work, hold the Down scroll button for a few seconds.
3. Make sure the battery is properly charged.
4. Perform a soft reset. Use a paperclip to gently press the reset button on the back of your handheld.
5. If your handheld still doesn't turn on, perform a hard reset by holding down the power button while doing a soft reset. Wait for the Palm Powered™ logo to appear, and then release the power button. If you want to continue and erase all your data, press the Up scroll button.

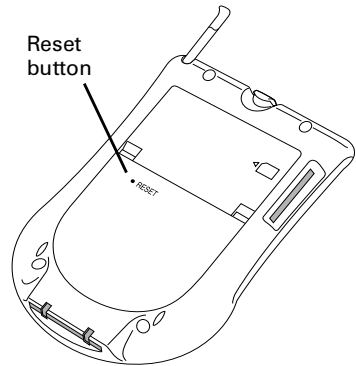

IMPORTANT With a hard reset, all records and entries stored in your handheld are erased. Never perform a hard reset unless a soft reset does not solve your problem. You can restore any data previously synchronized with your computer during the next HotSync operation. See the electronic *Handbook* for instructions on restoring your data.

I can't complete a HotSync operation

The first step in diagnosing HotSync problems is to determine if your handheld and computer are able to communicate with each other.

1. Connect your handheld to the HotSync cradle/cable.
2. Confirm that HotSync Manager is running and enabled.

Windows computer. On the Windows desktop, double-click the Palm Desktop icon, click the HotSync icon ™ on the taskbar and make sure Local (USB or Serial), depending on the kind of

connection you use) is checked on the menu. If not, click it to insert a check mark.

Mac computer. Double-click the HotSync Manager icon in the Palm folder. Click the HotSync Controls tab and make sure the Enabled option is selected.

3. Press the HotSync button  on the cradle/cable.
4. Watch your monitor to see if the HotSync Progress dialog box appears (you can also hear the HotSync tones on your handheld).

If the HotSync Progress dialog box does not appear, your handheld and computer are not communicating. See “Troubleshooting communication problems” later in this chapter.

If the HotSync Progress dialog box appears, your handheld and computer are communicating. See “Troubleshooting data synchronization problems” later in this chapter.



Troubleshooting communication problems

Check your connections:

1. Check the contact points on your handheld and on the HotSync cradle/cable and make sure they are clean and free from obstruction.
2. Make sure that your handheld is seated firmly on the HotSync cradle/cable.
3. Check the HotSync cradle/cable connection on the back of your computer to make sure it is properly attached.
4. Press the HotSync button on the cradle/cable to perform a HotSync operation.

If your problem persists, check your handheld settings.

Check your handheld settings:

1. Turn on your handheld and tap the Applications icon .
2. Tap the HotSync icon .

3. Tap Local above the HotSync icon and select Cradle/Cable from the pick list below the HotSync icon.
4. Tap the HotSync icon to perform a HotSync operation.
If your problem persists, check your computer settings.

Check your Windows computer settings:

1. Right-click the My Computer icon on your Desktop and choose Properties.
2. Click the Hardware tab, and then click Device Manager.
3. Click the plus sign (+) next to Ports.

If the port you are using for the HotSync cradle/cable shows an exclamation point, you have a hardware conflict. To resolve this, consult the documentation that came with your computer.

4. Click the HotSync icon  on the taskbar and choose Setup.
5. Click the Local tab and make sure the Serial port setting matches the port where you connected the HotSync cradle/cable.
6. From the Speed list, choose the 9600 setting.
7. Click OK and perform a HotSync operation. If you are still experiencing problems, complete steps 8 and 9.
8. Click the HotSync icon on the taskbar and choose Exit.
9. Restart HotSync Manager by selecting Start, Programs, Palm Desktop, and then HotSync Manager.

NOTE If you get a warning that the port is in use, then either move your HotSync cradle/cable to a different COM (serial) port or disable the conflicting device to perform HotSync operations.

Check your Mac computer settings:

1. Double-click the HotSync Manager in the Palm folder.
2. Click the Serial Port Settings tab.
3. Make sure Local is selected and that the port selection matches the port where your HotSync cradle/cable is attached.

NOTE If you get a warning that the port is in use, then either move your HotSync cradle/cable to a different port or disable the conflicting device to perform HotSync operations.

Troubleshooting data synchronization problems

If your data does not appear on your handheld and in Palm Desktop software after a HotSync operation, try the steps in this section.

NOTE If you are attempting to synchronize with applications other than the Palm Desktop software (for example, Microsoft Outlook or Lotus Notes) using a third-party conduit, please consult the documentation that was provided with that conduit.

Check your desktop configuration:

1. Make sure you selected the username that matches your handheld.
2. Make sure the date on your computer matches the date on your handheld.

Check the HotSync log:

1. Open the HotSync log.

Windows computer. Click the HotSync icon on the taskbar and select View Log from the menu.

Mac computer. Double-click the HotSync Manager in the Palm folder and choose View Log from the HotSync menu.

2. Ensure that all applications are marked OK. If not, continue to the next section to check your conduit settings.

Check your conduit settings on a Windows computer:

1. Click the HotSync icon on the taskbar and select Custom.
2. Select the username that matches the handheld you are attempting to synchronize.
3. Ensure that the application conduits (other than Backup and Install) are set to Synchronize the Files.

Check your conduit settings on a Mac computer:

1. Double-click the HotSync icon in the Palm folder.
2. From the HotSync Manager menu, choose Conduit Settings.
3. Select the username that matches the handheld you are attempting to synchronize.
4. Ensure that the application conduits (other than Backup and Install) are set to Synchronize the Files.

Troubleshooting recharging problems

When you place your handheld in the cradle, a lightning bolt on the battery icon in the Applications Launcher screen indicates that the battery is charging. If the lightning bolt does not appear on the battery icon, the battery might not be charging. Check the following:

1. Confirm that the handheld is well seated in the cradle.
2. Confirm that the recharger cable is properly connected to the back of the USB connector that plugs into your computer.
3. Confirm that your recharger is plugged into an AC outlet that has power.

TIP Turn off your handheld to minimize recharging time.

Troubleshooting expansion card problems

- Remove and reinsert the expansion card in the slot to ensure it is properly installed.

A

- Accessories, attaching 1
- Address Book 5
- Adobe Acrobat Reader for electronic *Handbook* 15
- Agenda view
 - in Date Book 6
 - showing To Do List items 9
- Alphabet
 - Graffiti writing 3
 - onscreen keyboard 2
- Applications
 - Address Book 5
 - beaming 11
 - buttons 1
 - Calculator 5
 - Card Info 5
 - Clock 6
 - Date Book 6
 - expansion card 11
 - Graffiti tutorial 6
 - HotSync 7
 - installing 15
 - Memo Pad 7
 - Note Pad 8
 - preferences 8
 - Security 9
 - starting 1, 4
 - third-party 16
 - To Do List 9
 - Welcome 9
- Applications Launcher 2, 4, 11
- Appointments in Date Book 6
- Attaching peripheral hardware 1

B

- Backing up your data 7, 14
- Backlight 1
- Basic Skills tutorial 4, 9

Battery

- charging 12
- troubleshooting recharging problems 21
- Beaming information 1, 11
- Bold text 7
- Business card, creating on handheld 11

C

- Calculator 2, 5
- Card Info for expansion cards 5, 11
- Categories
 - application 4
 - beaming 11
 - creating 4
 - expansion card 11
- Charging
 - troubleshooting problems 21
- Clock 6
 - alarm 2
 - alarm sounds 6
 - time and date 2
 - turning on with Up scroll button 1
 - viewing the time 1, 2
- Command stroke 10
- Commands
 - accessing 2
 - menus for 10
 - toolbar of common 10
- Connecting handheld 1
- Contrast
 - improving screen visibility 2
 - troubleshooting screen problems 17
- Cover for handheld 13
- Customizing handheld 8

D

- Data. *See* Entering text
- Date Book 6
- Date, setting and viewing 6
- Day view in Date Book 6
- Diamond mark for untimed event 6
- Documentation for handheld 4, 6, 15
- Downloading applications from the web 15
- Drawing in Note Pad 8

E

- Entering text
 - fonts 7
 - Graffiti tutorial 3, 4
 - help with Graffiti writing 4
 - on computer 14
 - on handheld 2
- Expansion card 10
 - formatting 5
 - installing applications on 15
 - naming 5
 - slot 1
 - troubleshooting 21

F

- Faceplate 1, 13
- Finding an address 5
- Finding text on handheld 2
- Flip cover for handheld 13
- Font, changing 7
- Frequently asked questions 16

G

- Graffiti writing
 - help for 4
 - Menu Command stroke 10
 - stylus used for 1
 - table of main characters 3
 - tutorial 3, 6, 9
 - where to write 1, 2
 - writing characters 3

H

- Handbook* 4, 15
- Handheld
 - attaching accessories to 1
 - cover for 13
 - faceplate for 13
 - increasing space on 10
 - locking 9
 - recalibrating screen 9
 - resetting 17
 - screen problems 17
- Handwritten notes 8
- Hard reset 17
- Hiding private records 9
- HotSync
 - connection 1
 - for installing applications 15
 - local operation on Mac computer 18
 - restoring data after hard reset 17
 - transferring data from computer to handheld 7, 14
 - troubleshooting problems 17–20

I

- Installing
 - applications 15
 - third-party applications 16
- International characters, onscreen keyboard 2
- IR port for beaming 1, 11

K

- Keyboards
 - external 1
 - on handheld 2

L

- Large text 7
- Locking handheld 9
- Looking up an address 5

M

Mac computer 15, 18, 20
 Masking private records 9
 Memo Pad 7
 Menus 2, 10
 Modem 1
 Month view in Date Book 6

N

Note Pad 8
 Notes
 Memo Pad 7
 Note Pad 8
 Numbers
 onscreen keyboard 2

P

Palm Desktop software 14
 Password 9
 Pen stroke 4
 Peripheral hardware, attaching 1
 Pick lists 4, 8
 Preferences 8
 Prioritizing tasks 9
 Private records 9
 Punctuation, Graffiti writing 3

R

Recalibrating handheld screen 9
 Records
 beaming 11
 entering text 3
 private 9
 Reminders 9
 Removing
 cover 13
 faceplate 13
 Resetting handheld
 hard reset 17
 soft reset 17
 Returning to handheld
 applications from expansion
 card 11

S

Scheduling with Date Book 6
 Screen
 contrast 2
 problems with 17
 recalibrating 9
 Scroll bar 1, 4
 Scroll buttons 1
 Security 9
 Soft reset 17
 Starting applications 1, 4
 Stylus 1
 to display Graffiti Help 4
 using to scroll 4
 Synchronization 7, 14
 See also HotSync

T

Tapping to work with handheld
 features 1
 Technical Support 16
 Third-party applications on
 handheld 16
 Time, setting and viewing 1, 6
 Tips for help on handheld 4
 To Do List 9
 Toolbar of common commands 10
 Troubleshooting 16–20
 Turning off handheld 1
 Turning on handheld 1, 17
 Tutorials on the handheld 4, 9

U

Universal connector 1
 Untimed events in Date Book 6

W

Web site 16
 Week view in Date Book 6
 Welcome 9
 Windows 15, 17, 20
 Writing on handheld 1, 2, 3

Palm, Inc.
5470 Great America Parkway
Santa Clara, California 95052
United States of America

www.palm.com

PN: 406-3996A-US